

Correct as at 23rd November 2013. It may be superseded at any time.

Extract taken from: NZTA Vehicle Portal > VIRMs > In-service certification (WoF) > General vehicles > Tyres, wheels and hubs

## 10 Tyres, wheels and hubs

### 10-1 Tyres and wheels

---

#### Reasons for rejection

##### Mandatory equipment

##### Tyres

1. Tyres on the same axle are not of the same:

- a) size designation, or
- b) carcass type (ie mixed steel ply, fabric radial ply, bias/cross ply, run-flat), or
- c) tread pattern type (mixed asymmetric, directional, normal highway, traction , winter tyre tread (**Figure 10-1-3**)).

2. All the tyres on a vehicle class MA, MB, MD1 or NA that was first registered or re-registered in New Zealand from 1 October 2002, other than vehicles that are incapable of exceeding 30km/h or are 30 years old or more, are not of the same carcass type (ie mixed steel ply, fabric radial ply, bias/cross ply, run-flat).

3. A class MA, MB, MC, MD1, MD2 or NA vehicle fitted with a winter tyre ([Note 3](#)) is not fitted with winter tyres on all road wheels.

4. The tyres on an axle of a light vehicle do not meet at least one of the following:

- the tyre ply ratings are the same
- the tyre load indices differ by no more than 2 ([Note 4](#)).

5. An asymmetric tyre is fitted to a vehicle with the 'inside' tyre wall facing outwards.

6. A directional tyre is fitted contrary to its correct direction of rotation.

7. A tyre has a speed category that is less than the speed limit for the vehicle or less than the vehicle's maximum speed if this is less than the speed limit ([Note 4](#)) ([Note 5](#)).

8. The vehicle has one or more of the following types of tyre fitted:

- a) a space-saver tyre, or
- b) a non-pneumatic tyre, or
- c) a tyre with studs, cleats, lugs or other gripping devices, or
- d) a tyre that is not compatible with the vehicle to which it is fitted, eg a tyre is marked with any of the following:
  - i. 'NOT FOR HIGHWAY USE'
  - ii. 'NHS' (Not for Highway Service)
  - iii. 'FOR TRAILER USE ONLY'
  - iv. 'ADV' (Agricultural Drawn Vehicle)
  - v. 'RACING PURPOSES ONLY'.
- e) a tyre that has had all its manufacturer / brand / model information removed so that the tyre can no longer be identified (**Figure 10-1-4**).

##### Wheels

9. A wheel is not compatible with the tyre fitted to it for rim profile, flange height or valve fitment ([Note 6](#)).

10. A wheel is:

- a) not compatible with the vehicle to which it is fitted, or
- b) not correctly attached to the vehicle.

## Condition

### Tyres (excluding spare tyres)

11. There are signs that a tyre is fouling on another part of the vehicle.

12. A tyre shows damage that is likely to compromise its ability to operate in a safe manner or lead to premature tyre failure, such as:

- a) a lump or bulge that is likely to be caused by separation or partial failure of the tyre structure, or
- b) a cut or crack in a sidewall or tread more than 25mm long that reaches the cords, or
- c) exposed or cut cords, or
- d) the tread of a retreaded tyre shows signs of separation, or
- e) nails or other sharp objects embedded in the tyre, or
- f) significant perishing, eg due to age, moisture or exposure.

13. A tyre has a string-type repair visible from the outside.

14. A tyre, other than a winter tyre ([Note 3](#)), fitted to a vehicle capable of exceeding 30km/h, does not have a tread pattern depth ([Technical bulletin 7](#)) of at least 1.5mm (excluding any tie-bar or tread-depth indicator strip) around the whole circumference of the tyre:

- a) within all the principal grooves that normally contain moulded tread depth indicators, or
- b) if the tyre does not normally have moulded tread-depth indicators (such as some retreaded or vintage tyres), across at least three-quarters of the tread width.

15. A winter tyre ([Note 3](#)) does not have a tread depth of at least 4mm (excluding any tie-bar or tread-depth indicator strip) within all principal grooves that normally contain moulded tread-depth indicators and around the whole circumference of the tyre.

16. A tyre not identified as designed for regrooving has had its tread depth increased by regrooving.

17. A tyre is noticeably under- or over-inflated.

### Spare tyres

18. A spare tyre, if carried is not:

- a) securely attached by a device that is in good condition and correctly applied, or
- b) stowed in a closed compartment separate from the occupant space (eg if the manufacturer's attachment device is missing or faulty).

## Wheels

19. There are signs that a wheel is fouling on another part of the vehicle.

20. A wheel is:

- a) cracked, or
- b) significantly damaged, distorted or has deteriorated, or
- c) not securely attached to the hub.

21. An alloy wheel has poor visible repairs.

22. A wheel nut is:

- a) missing, or
- b) loose, or
- c) has deteriorated, or
- d) is of the incorrect type, or

e) has insufficient thread engagement to the wheel stud.

## Modifications

23. A modification affects the wheels or tyres, and:

- a) is not excluded from the requirements for LVV specialist certification (**Table 10-1-1**), and
- b) is missing proof of LVV specialist certification, ie:
  - i. the vehicle is not fitted with a valid LVV certification plate, or
  - ii. the operator is not able to produce a valid modification declaration or authority card.

### Note 1

Tread pattern and tread depth requirements do not apply to vehicles that are not capable of exceeding 30 km/h.

### Note 2 Definitions:

**Asymmetric tyre** means a tyre which, through tread pattern or construction, is required to be fitted to a vehicle so that one particular side wall faces outwards.

**Construction** in relation to a tyre means:

- a) for a pneumatic tyre, the type of tyre carcass (including ply orientation and ply rating or load index, but not including tyre tread), or
- b) for any other tyre, characteristics relating to size, shape and material.

**Cross-ply** means a pneumatic tyre structure in which the ply cords in the tyre carcass extend to the beads and are laid at alternate angles, which are substantially less than 90 degrees, to the centreline of the tread. This tyre structure is also referred to as 'bias ply' or 'diagonal ply'.

**Directional tyre**, also known as **unidirectional tyre**, means a tyre with a tread pattern that is designed to run in only one direction. A directional tyre usually has an arrow marked on the side wall indicating the direction it is designed to run.

**Load index** is an assigned number ranging from 0 to 279 that corresponds with the maximum load-carrying capacity of the tyre. Most passenger car tyre load indices range from 62 (= 265kg) to 126 (= 1700kg).

**Modify** means to change a vehicle from its original state by altering, substituting, adding or removing a structure, system, component or equipment, but does not include repair.

**Ply rating** is an index of tyre strength used to identify a given tyre with its recommended maximum permitted load when used for a specific service. It does not necessarily represent the actual number of plies in a tyre. Common ply ratings are 2, 4, 6, 8, 10 and 12. Commercial (eg truck) tyres often have a ply rating rather than a load index.

**Pneumatic tyre** means a tyre that, when in use, is inflated by air or gas introduced from time to time under pressure so as to enclose under normal inflation a cushion of air or gas forming altogether at least half of the total area of an average cross-section of a tyre so inflated.

**Principal grooves** means the wide grooves in the tyre tread which have the tread-wear indicators located inside them. Any other grooves are secondary grooves which may wear out during the service life of the tyre.

**Radial-ply** means a pneumatic tyre structure in which the ply cords, which extend from bead to bead, are laid at approximately 90 degrees to the centreline of the tread, the carcass being stabilised by an essentially inextensible circumferential belt.

**Repair** means to restore a damaged or worn vehicle, its structure, systems, components or equipment to within safe tolerance of its condition when manufactured, including replacement with undamaged or new structures, systems, components or equipment.

**Rim** means that part of the wheel on which the tyre is mounted and supported.

**Run-flat tyre** (also known as self-supporting tyre) means a tyre that is so constructed that in case of a puncture the basic tyre functions are still provided for a short distance (at least 80km) and at a reduced speed (usually 80km/h), allowing the vehicle to be safely driven to a place of repair. Some run-flat tyres are identified by an 'F' within the size designation.

**Size designation** means the size description of the tyre, ie section width, aspect ratio and rim diameter. It does not include the speed rating, load index or tyre construction (eg 'R' for radial).

**Space saver tyre** (temporary-use spare tyre) means a combination tyre and wheel designed and constructed solely for temporary use under restricted driving conditions, and not intended for use under normal driving conditions.

**Speed category** means a code allocated to a tyre by a tyre manufacturer that indicates the maximum vehicle speed for which the use of the tyre is rated.

**Tread** means that part of a pneumatic tyre which comes into contact with the ground.

**Tread-depth indicator** (or tread-wear indicator) means the projections within the principal grooves designed to give a visual indication of the degree of wear of the tread. To help locate these on a tyre, inspectors should look for a  or 'TWI' mark on the outer edge of the tyre side wall (most tyres have these marks).

**Tube** means an inflatable elastic liner, in the form of a hollow ring fitted with an inflation valve assembly, designed for insertion into certain tyre assemblies to provide a cushion of air or gas that, when inflated, supports the wheel (also known as an 'inner tube').

**Tyre carcass** means the structural part of a pneumatic tyre other than the tread and outermost rubber of the sidewalls that, when inflated, contains the gas that supports the load. Carcass type refers to steel ply, fabric radial ply, bias/cross ply, run-flat.

**Tyre load rating** means the maximum load a tyre can carry at the corresponding cold inflation pressure prescribed by the tyre manufacturer and the speed indicated by its speed category symbol. It is usually indicated by the load index or ply rating.

**Wheel** means a rotating load-carrying member between the tyre and the hub, which usually consists of two major parts, the rim and the wheel disc, and which may be manufactured as one part, or permanently attached to each other, or detachable from each other.

**Wheel centre-disc** means the part of the wheel that is the supporting member between the hub and the rim.

**Wheel spacer** means an additional component used for the purpose of positioning the wheel centre-disc relative to the hub or, in multiple wheel sets, for the purpose of positioning the wheel centre-disc relative to another wheel.

### **Note 3**

**Winter tyre** means a tyre which is principally designed to be operated at temperatures of less than 7 °C. A winter tyre can be identified by its distinctive tyre tread pattern consisting of deep tread blocks with wavy sipes and is always marked with the word 'STUDLESS' and/or a symbol of a snowflake and mountain on the sidewall (see **Figure 10-1-3**).

### **Note 4**

The tyre load index and speed category are usually marked on the tyre. Where the tyre is not marked, the load and speed rating information must be obtained from the tyre manufacturer or a reference guide of tyre ratings before the tyre can be passed.

### **Note 5**

Sometimes a retreaded or repaired tyre has had its speed rating removed. Where a tyre has been repaired or retreaded in accordance with standard NZS 5423 (Repairing and retreading car, truck and bus tyres), the tyre must be marked with NZS 5423 and, if a car tyre, have the speed rating removed. In such a case, a missing speed rating is acceptable for WoF/CoF (unless the inspector believes on reasonable grounds that the tyre would not have had the required minimum speed rating for the vehicle in the first place).

### **Note 6**

If there is any doubt about the compatibility of a tyre/wheel combination, the vehicle inspector may request/ take into account relevant information provided by the tyre manufacturer.

## **Table 10-1-1. Modifications that do not require LVV certification**

Fitting of or modification to:	LVV certification is not required provided that:
Aftermarket wheel fitments <sup>1</sup>	<ul style="list-style-type: none"> <li>• the wheels: <ul style="list-style-type: none"> <li>– are of a known and reputable brand, and</li> <li>– would be considered an appropriate fitment for the vehicle type by the wheel manufacturer, and</li> <li>– are not modified, and</li> <li>– do not have spacers or adaptors fitted.</li> </ul> </li> <li>• the tyre tread: <ul style="list-style-type: none"> <li>– does not protrude beyond the unmodified original body panels (including unmodified factory-fitted mudguard extensions), or</li> <li>– protrudes beyond the unmodified original body panels, but is covered by aftermarket or modified mudguard extensions or modified body panels, and the track width has increased by no more than 25mm from OE.</li> </ul> </li> </ul>
Tyre size changes	<ul style="list-style-type: none"> <li>• the tyres: <ul style="list-style-type: none"> <li>– have an outer circumference that is no more than 5% greater than OE, and</li> <li>– are an appropriate selection for rim width, and</li> <li>– have tread that does not extend beyond the original or modified body panels or guard extension (see <b>Figure 10-1-1</b>).</li> </ul> </li> </ul>

<sup>1</sup> The vehicle inspector may refer the vehicle to an LVV certifier if the inspector has reasonable concerns that the safety of the vehicle has been affected by an aftermarket wheel fitment.

Fitting of or modification to:	LVV certification is never required:
Any modification for the purposes of law enforcement or the provision of emergency services	<ul style="list-style-type: none"> <li>• in-service requirements for condition and performance must be met.</li> </ul>

**Table 10-1-2. Tyre speed symbol categories**

Speed symbol – speed category (km/h)							
A1 – 5	A5 – 25	B – 50	F – 80	L – 120	Q – 160	U – 200	Y – 300
A2 – 10	A6 – 30	C – 60	G – 90	M – 130	R – 170	H – 210	ZR – over 240
A3 – 15	A7 – 35	D – 65	J – 100	N – 140	S – 180	V – 240	
A4 – 20	A8 – 40	E – 70	K – 110	P – 150	T – 190	W – 270	

**Table 10-1-3. Tyre interchangeability – imperial and metric**

Imperial sizing	Metric sizing
10/70R22.5	255/70R22.5
11/70R22.5	275/70R22.5
12/70R22.5	305/70R22.5
15R22.5	385/65R22.5
16.5R22.5	425/65R22.5

Figure 10-1-1. Tyre and body panel position

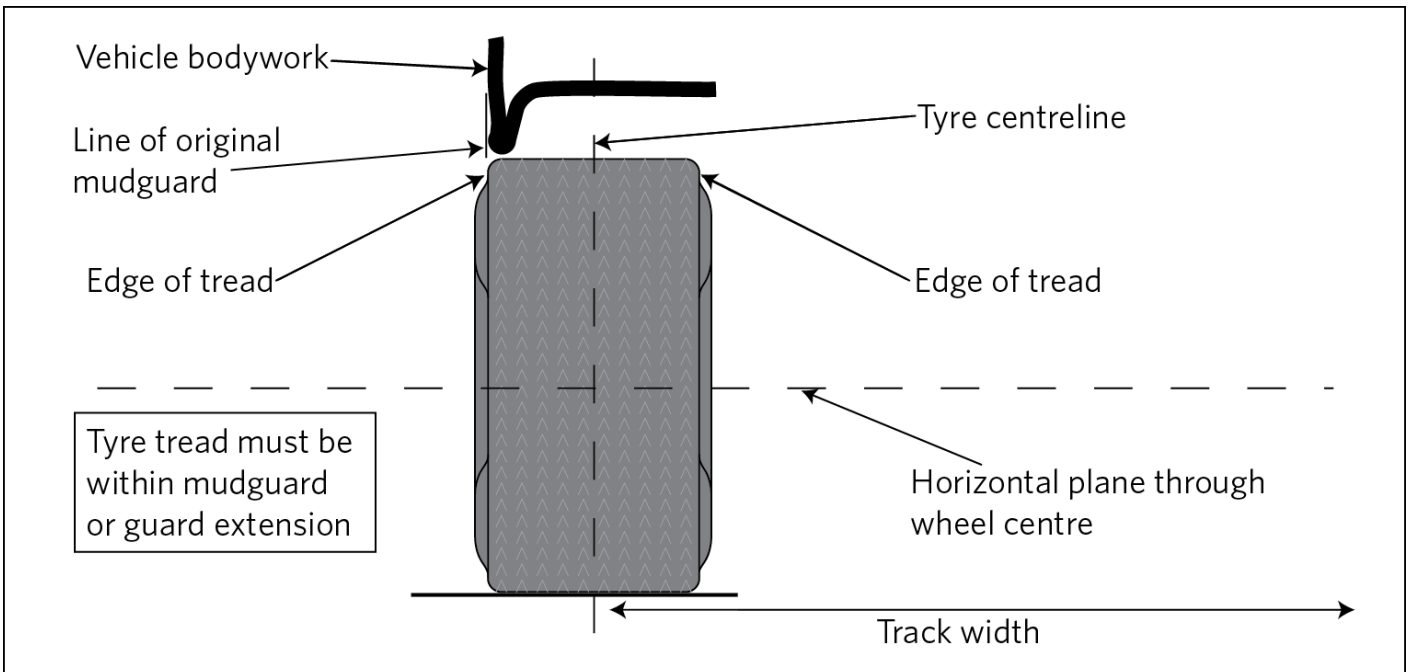

Figure 10-1-2. Tyre markings

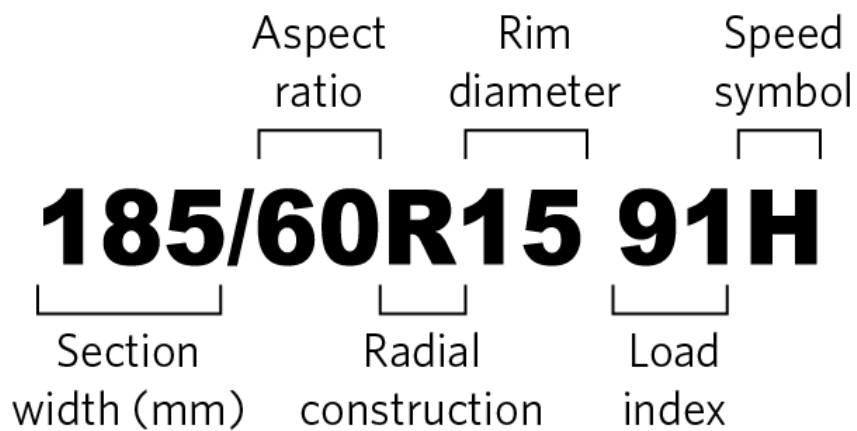

Figure 10-1-3. How to identify a winter tyre



Sample winter tyre tread



Mountain and snowflake symbol



Example of 'Studless' on a tyre sidewall

**Note:** For WoF purposes, a tyre is considered to be a winter tyre only if it has BOTH a winter tyre tread AND a studless marking and/or mountain/snowflake symbol.

**Figure 10-1-4. Example of tyre with manufacturer/brand/model information removed**

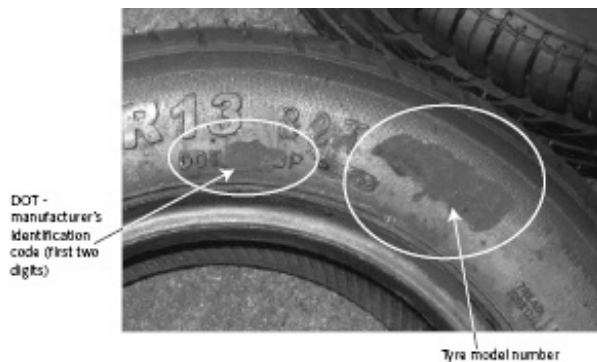

The circled areas show where information has been removed so that the tyre can no longer be identified.



# Summary of legislation

## Applicable legislation

- [Land Transport Rule: Tyres and Wheels 2001](#).

## Mandatory equipment

### Tyres

1. Tyres must be compatible with the vehicle to which they are fitted.
2. Tyres on the same axle must be of the same size designation and construction, and of the same tread pattern type.
3. A vehicle of class MA, MB, MD1 or NA first registered or re-registered in New Zealand from 1 October 2002, must have all tyres of the same construction unless the vehicle is incapable of exceeding 30km/h or is 30 years old or more.
4. Winter tyres ([Note 3](#)), if fitted to a class MA, MB, MC, MD1, MD2 or NA vehicle, must be fitted to all of the vehicle's road wheels.
5. Asymmetric tyres must be fitted in axle sets in accordance with manufacturer's instructions.
6. A directional tyre must be fitted to a wheel position corresponding to its direction of rotation.
7. The speed category of a tyre must be compatible with the maximum legal speed limit for the vehicle, or the vehicle's maximum speed ([Note 4](#)) ([Note 5](#)).
8. A vehicle must not be fitted with a metal tyre or other non-pneumatic tyre, or with a tyre with studs, cleats, lugs or other gripping devices.

### Wheels

9. A wheel must be:
  - a) sufficiently strong for the type of vehicle to which it is fitted, and
  - b) compatible with the vehicle to which it is fitted, and
  - c) compatible with the tyre rim profile, flange height and valve fitment ([Note 6](#)).
10. There must be adequate clearance for the brake, hub, suspension and steering mechanism, and body parts.

## Permitted equipment

11. A vehicle may be fitted with retreaded tyres.

## Condition

### Tyres (excluding spare tyres and space-saver tyres)

12. A tyre must be of good quality and construction, fit for its purpose, and maintained in a safe condition.
13. A tyre must not have worn, damaged or visible cords apparent by external examination.
14. A tyre, other than a winter tyre, fitted to a vehicle capable of exceeding 30km/h, must have a tread pattern depth of not less than 1.5mm (excluding any tie-bar or tread-depth indicator strip) around the whole circumference of the tyre:
  - a) within all principal grooves that contain tread-depth indicators, or
  - b) if the tyre does not normally have tread-depth indicators, across at least three-quarters of the tyre tread width.
15. A winter tyre ([Note 3](#)) must have a tread pattern depth of not less than 4mm (excluding any tie-bar or tread-depth indicator strip) within all principal grooves that contain moulded tread-depth indicators and around the circumference of the tyre.
16. The regrooving of a tyre is permitted only if the tyre is identified as having been specifically designed for regrooving after manufacture.
17. A tyre that is fitted to a vehicle must be maintained at a safe inflation pressure.

### Spare tyre

18. If the vehicle carries a spare tyre, the tyre must be securely attached on or in the vehicle.

### Wheels

19. The components of the wheel assembly must be in good condition.
20. The wheel must be securely attached to the hub.

## Modifications



21. A modification that affects the wheels or tyres must be inspected and certified by an LVV Specialist Certifier, unless the vehicle is:

- a) excluded from the requirement for LVV specialist certification (**Table 10-1-1**), and has been inspected in accordance with the requirements in this manual, including those for equipment, condition and performance, or
- b) fitted with a wheel spacer that is approved for the purpose by the vehicle, wheel or axle manufacturer, or
- c) fitted with a hand-grooved tyre, provided the tyre was a blank tyre case manufactured for hand-grooving, and complies with the applicable listed requirements.

## 10-2 Hubs and axles

---

### Reasons for rejection

#### Condition

1. A hub:

- a) is not securely attached to the vehicle, or
- b) has a visible crack, or
- c) is significantly damaged, distorted or has deteriorated, or
- d) has a broken or missing wheel stud.

2. A wheel bearing:

- a) has play beyond the manufacturer's specifications, or
- b) is over-tight or sounds rough.

3. An axle:

- a) is insecure, eg has loose U-bolts, or
- b) is visibly cracked, or
- c) is significantly damaged, distorted or has deteriorated, or
- d) shows signs of welding or heating after original manufacture, or
- e) shows signs of fouling the vehicle structure or a brake, suspension or steering component.

#### Performance

4. The geometry of a hub or axle causes:

- a) the vehicle to veer significantly to one side, or
- b) the wheels not to self centre.

#### Modification

5. A modification affects the hubs or axles, and:

- a) is not excluded from the requirements for LVV specialist certification (**Table 10-2-1**), and
- b) is missing proof of LVV specialist certification, ie:
  - i. the vehicle is not fitted with a valid low volume vehicle certification plate, or
  - ii. the operator is not able to produce a valid modification declaration or authority card.

#### Note 1 Definitions

**Hub** means that part of a vehicle that is attached to the axle and rotates on, or with, the axle, and to which the wheel is attached, and includes any bearings.

**Modify** means to change a vehicle from its original state by altering, substituting, adding or removing a structure, system, component or equipment, but does not include repair.

**Repair** means to restore a damaged or worn vehicle, its structure, systems, components or equipment to within safe tolerance of its condition when manufactured, including replacement with undamaged or new structures, systems, components or equipment.

**Table 10-2-1. Modifications that do not require LVV certification**

Fitting of or modification to:	LVV certification is not required provided that:
Differential ratio changes	<ul style="list-style-type: none"> <li>only the differential centre or gear-set is changed, and</li> <li>the OE axle housing is retained.</li> </ul>
Axle housing replacement	<ul style="list-style-type: none"> <li>the axle housing fits the vehicle without adaptation, and</li> <li>no change to the OE suspension geometry occurs, and</li> <li>the OE drive-shafts(s) is unmodified, and</li> <li>no changes are made to the OE brake system.</li> </ul>

Fitting of or modification to:	LVV certification is never required:
Any modification for the purposes of law enforcement or the provision of emergency services	<ul style="list-style-type: none"> <li>in-service requirements for condition and performance must be met.</li> </ul>

## Summary of legislation

### Applicable legislation

- [Land Transport Rule: Tyres and Wheels 2001.](#)

### Condition

- The components of the assembly must be in good condition.
- The hub and axle must be sufficiently strong for the type of vehicle to which they are fitted.
- The hub and axle must have a suitable and correctly adjusted geometry.

### Modification

- A modification that affects the hubs or axles must be inspected and certified by a Low Volume Vehicle Specialist Certifier, unless the vehicle:
  - is excluded from the requirement for LVV specialist certification (**Table 10-2-1**), and
  - has been inspected in accordance with the requirements in this manual, including those for equipment, condition and performance.

## 10-3 Mudguards

### Reasons for rejection

#### Mandatory equipment

- A mudguard over a road wheel is missing where it is reasonable and practicable to fit a mudguard, unless the vehicle is:
  - in an unfinished condition legally used under the authority of trade plates, or
  - not capable of exceeding a speed of 30km/h, or
  - has a valid mudguard exemption issued by the New Zealand Hot Rod Association (**Figure 10-3-4**).
- A mudguard does not cover the full tread width (**Note 2**) of a tyre or tyres fitted to a road wheel (**Figure 10-3-1** and **Figure 10-3-2**), except when the mudguard is fitted to a vehicle designed for industrial purposes and it is not practicable to fit a full mudguard due to the vehicle's construction.
- On a vehicle with twin or close-spaced multiple tyres a mudguard fitted over a wheel on the rear axle is more than one-third higher than the horizontal distance between the vertical lines of the lowest point of the mudguard and the centre of the wheel (**Figure 10-3-3**), except when:

a) the mudguard is fitted to a vehicle designed for industrial purposes and it is not practicable to fit a full mudguard due to the vehicle's construction.

### Mudguard condition

4. A mudguard is not securely fixed to the vehicle.
5. A mudguard is so constructed or damaged that it is likely to present a hazard to road users ([Note 2](#)).

### Modification

6. A modification affects a mudguard, and:
  - a) is not excluded from the requirements for LVV specialist certification ([Table 10-3-1](#)), and
  - b) is missing proof of LVV certification, ie:
    - i. the vehicle is not fitted with a valid low volume vehicle certification plate, or
    - ii. the operator is not able to produce a valid modification declaration or authority card.

### Note 1 Definitions

**Mudguard** means a fitting, inclusive of any portion of the vehicle and of any mudflaps attached, that serves to intercept material thrown up by a wheel more or less in the plane of the wheel.

**Tyre tread** means the portion of a tyre that contacts the road.

**Modify** means to change a vehicle from its original state by altering, substituting, adding or removing a structure, system, component or equipment, but does not include repair.

**Repair** means to restore a damaged or worn vehicle, its structure, systems, components or equipment to within safe tolerance of its condition when manufactured, including replacement with undamaged or new structures, systems, components or equipment.

### Note 2

Damage on full mudguards fitted to logging trucks is permissible if it is above a horizontal line on top of the tyre ([Figure 10-3-5](#)), and that damage is unlikely to result in the mudguard presenting a hazard to road users.

**Table 10-3-1. Modifications that do not require LVV certification**

Fitting of or modification to	LVV certification is never required:
Modified mudguards, including flared wheel arches or the addition of mudguard extensions <sup>1</sup>	<ul style="list-style-type: none"><li>• in-service requirements for condition and performance must be met. (see also <a href="#">Table 10-1-1</a>)</li></ul>
Any modification for the purposes of law enforcement or the provision of emergency services	

<sup>1</sup> Some vehicles fitted with flared wheel arches or mudguard extensions will require LVV certification as a result of aftermarket wheel fitments and tyre size changes. See [Table 10-1-1](#).

**Figure 10-3-1. Position of individual mudguard in relation to tyre tread**

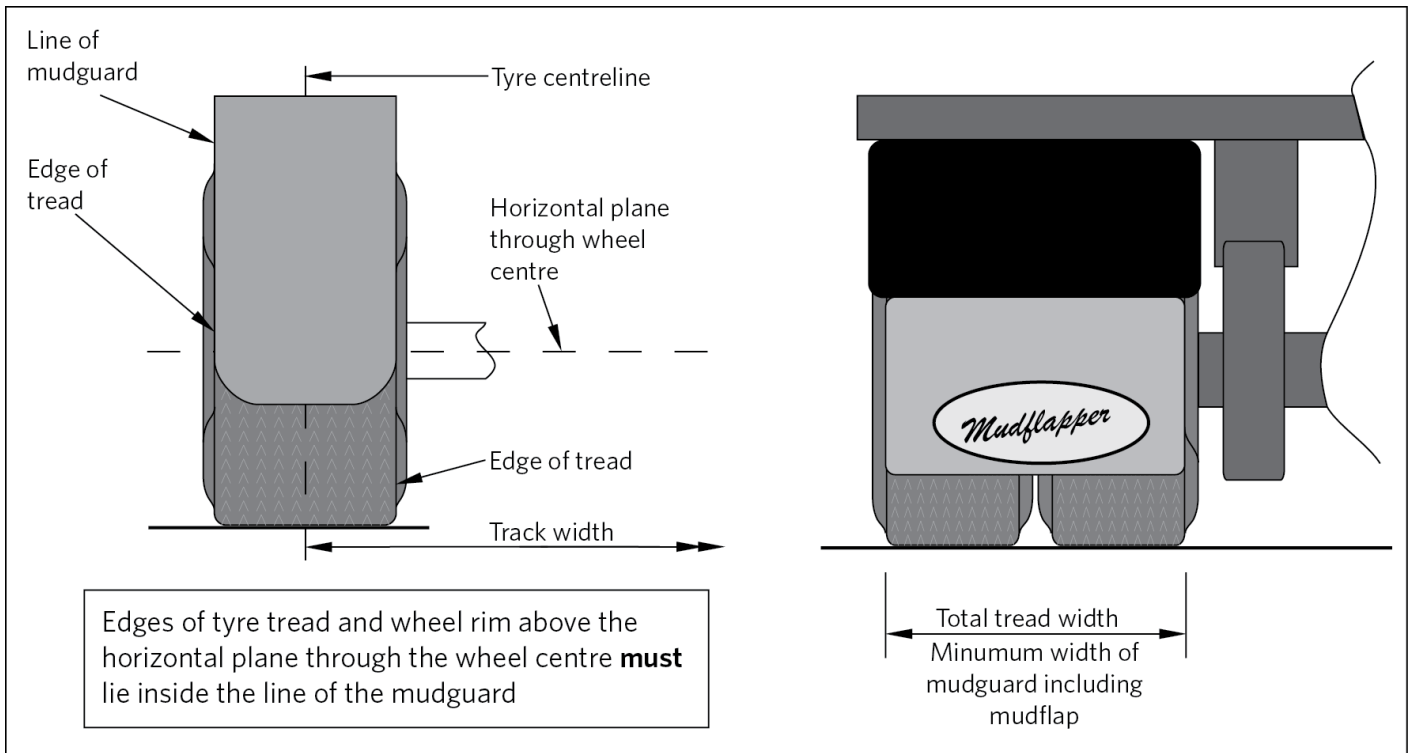

**Figure 10-3-2. Position of body panel mudguard in relation to tyre tread**

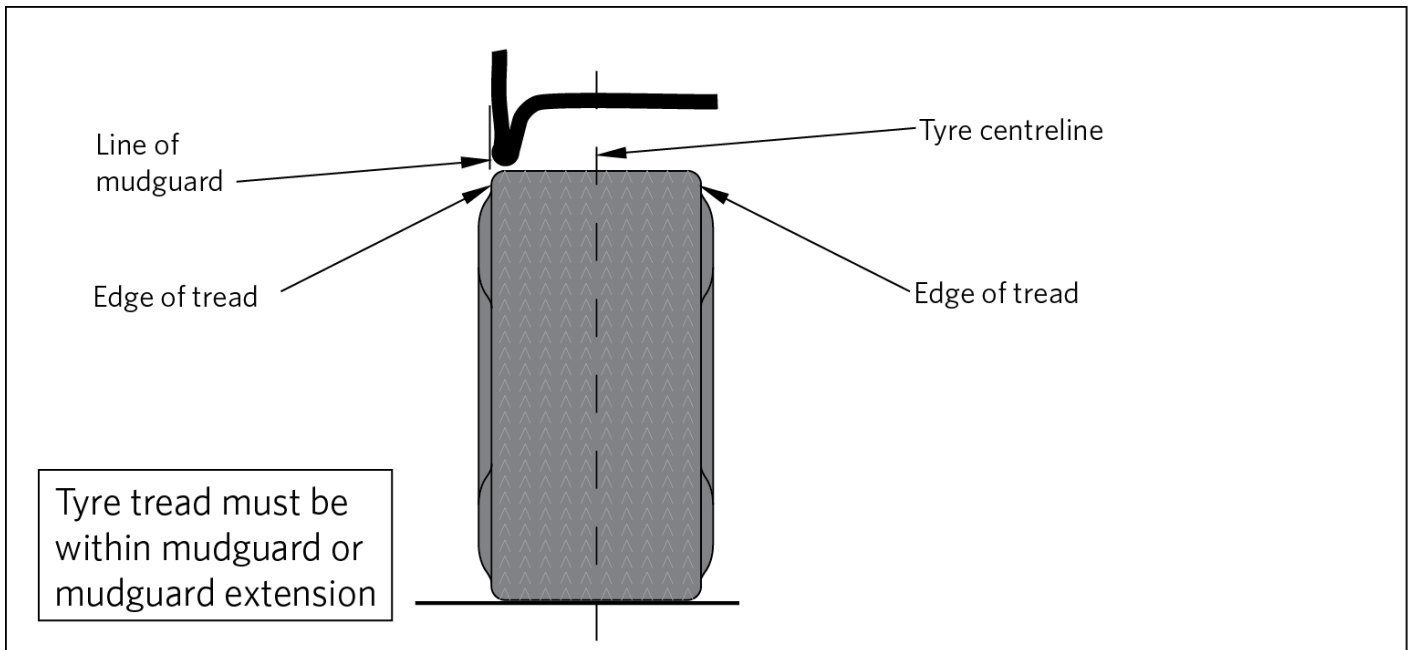

**Figure 10-3-3. Size and position of mudguards for the rear wheels of a vehicle fitted with dual wheels or close-spaced multiple wheels**

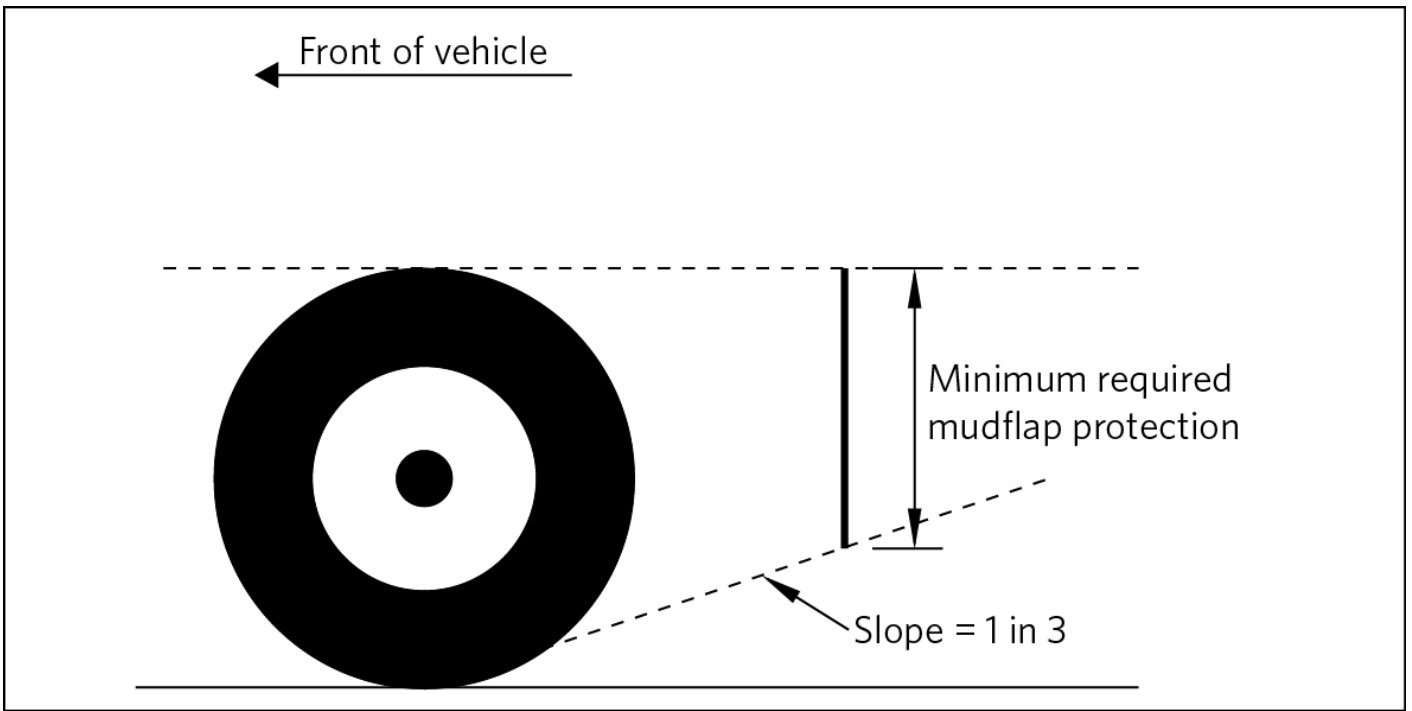

Figure 10-3-4. LVV Authority Card: New Zealand Hot Rod Association

**LV** Low Volume Vehicle Technical Association Inc.

## LOW VOLUME VEHICLE AUTHORITY CARD

The following modifications are authorised under section 2.12 of the Low Volume Vehicle Code (refer to back of Authority Card for conditions of use).

- 1.
- 2.
- 3.
- 4.
- 5.
- 6.

**Name:**  
**Vehicle:**  
**Issued by:** NZ Hot Rod Association  
**Issue date:**  
**LVV Authority Card #:** HR

**Licence #:**  
**VIN:**  
**Reg. No (optional):**  
**Logbook #:**  
**LVV Cert Plate #:**

**Valid Until:**

Figure 10-3-5. Permissible damage area on logging truck mudguards ([Note 2](#))

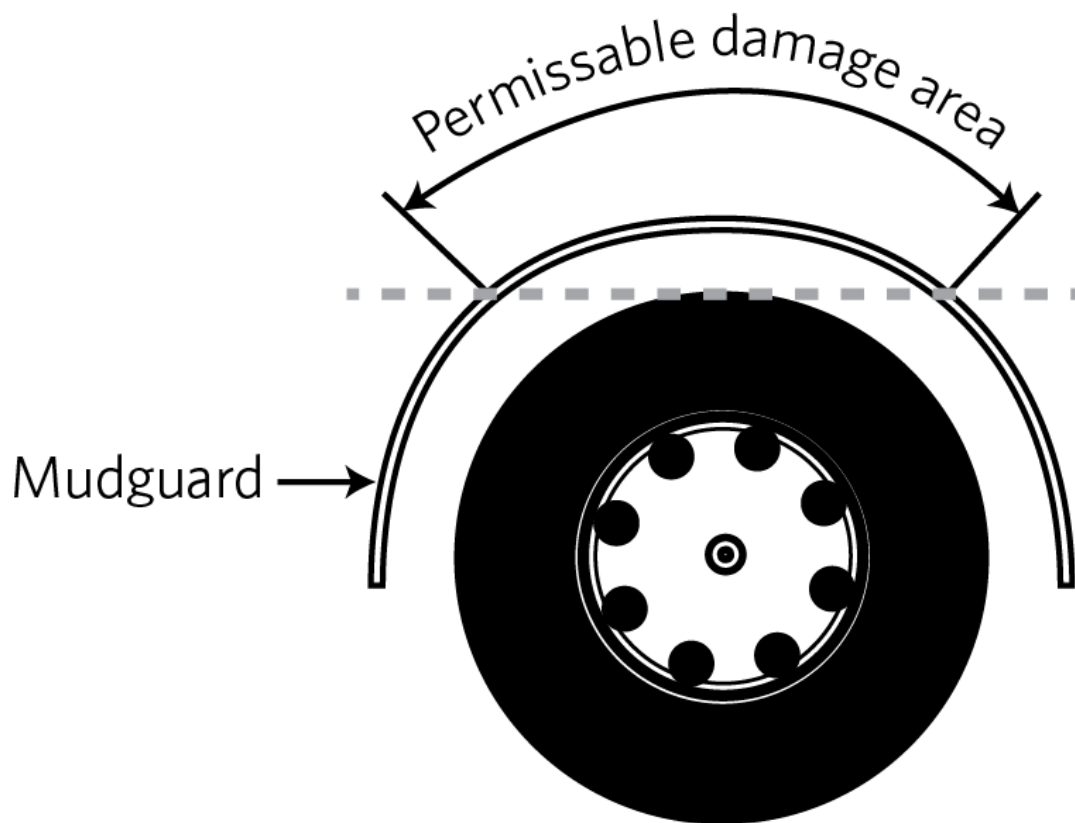

## Summary of legislation

### Applicable legislation

- [Land Transport Rule: Tyres and Wheels 2001](#).

### Mandatory equipment

1. A vehicle must be fitted with a mudguard over each road wheel if it is reasonable and practicable to do so ([Note 1](#)).
2. A mudguard must cover no less than the width of the tyre tread on each road wheel (**Figure 10-3-1** and **Figure 10-3-2**).
3. A vehicle fitted with twin tyres or close-spaced multiple tyres must be fitted with a mudguard over each wheel on the rear axle that provides continuous protection from a horizontal line tangent to the top of the tyre tread ([Note 2](#)) to a line with a slope of 1 in 3 rising rearward from the tyre's contact point on the road (**Figure 10-3-3**).
4. A vehicle designed for industrial purposes may be fitted with partial mudguards if the vehicle's construction makes it impracticable to fit full mudguards.
5. The following vehicles are not required to be fitted with mudguards:
  - a) a vehicle in an unfinished condition used under the authority of trade plates and operated in accordance with the Compliance Rule
  - b) a vehicle not capable of exceeding a speed of 30 km/h
  - c) a vehicle with a valid LVV authority card (**Figure 10-3-4**).

### Mudguard condition

6. A mudguard must be securely fixed to the vehicle and must be constructed so that it does not present a hazard to road users.

### Modification

7. A modification that affects a mudguard must be inspected and certified by a Low Volume Vehicle specialist certifier, unless the vehicle:
  - a) is excluded from the requirement for LVV certification (**Table 10-3-1**), and
  - b) has been inspected in accordance with the requirements in this manual, including those for equipment, condition and performance.